

LèPRESSO



LePresso

**Fully Automatic Ice and Hot
Coffee Machine**

SKU: LPYKFM12D03BK

Table of Contents

Safety Precautions	2
Schematic View	5
Control Panel Guide	6
Specifications	7
Instructions for Use	7
Power Button Guide	10
Making Iced Coffee	11
Making Hot Coffee	12
Time Setting	12
Reservation Button	13
Keep Warm Function	14
Ice-Making Function	14
Indicator and Icon Guide	16
Cleaning Guide	18
Troubleshooting	22
List of Food Contact Materials	25
Environmental Checklist	26
Disposal	27
Warranty	28
Contact Us	28

Safety Precautions

- 1.** Please read this instruction manual carefully before using the product and keep it in a safe place for future reference.
- 2.** The input voltage of this product is 220-240V~50Hz. Before connecting to the power supply, ensure compatibility with your local voltage. Using a voltage higher or lower than specified may damage the product. To avoid damage, it is recommended to use a voltage regulator and a separate, properly grounded power outlet.
- 3.** Always unplug the product from the power supply before disassembling, adjusting, or cleaning any part to prevent electrical shock or accidental activation.
- 4.** Do not place the product on or near gas, electric, or heated ovens.
- 5.** Keep the product out of reach of children and individuals with limited mobility. Do not allow them to use the product unsupervised to avoid risks such as burns or electric shock.
- 6.** Keep hands, utensils, and other objects away from the container during use to minimize the risk of injury or damage.
- 7.** To prevent fire, electric shock, or injury, never immerse the power cord, plug, heating base, or the entire appliance in water or other liquids.
- 8.** Appliances should always be used under close supervision when children are nearby.
- 9.** Avoid contact with steam or hot surfaces to prevent burns.
- 10.** Avoid contact with any moving parts of the appliance.
- 11.** Use only accessories recommended or supplied by the manufacturer; use of unauthorized accessories may result in fire, electric

shock, or injury.

12. Do not operate the appliance if the power cord or plug is damaged, or if the appliance malfunctions, has been dropped, or damaged. Contact the store of purchase or customer service for assistance.

13. This appliance is equipped with a grounding plug. Ensure the wall outlet is properly grounded.

14. This appliance is intended for household use only.

15. Children must be supervised to ensure they do not play with the appliance as a toy.

16. Disconnect the appliance from the power supply before assembling, disassembling, or cleaning.

17. After use, allow the heating element surface to cool before touching to avoid burns.

18. Do not place the coffee maker inside a cupboard while in operation.

19. If the power cord is damaged, it must be replaced by the manufacturer, its service department, or a qualified technician to avoid hazards.

20. The appliance must not be immersed in liquids.

21. Do not store explosives, flammable sprays, or accelerants near or inside the appliance. This product is intended for household and similar uses, such as kitchens in shops, offices, farms, hotels, motels, and residential environments. It is not designed for commercial use in businesses, hotels, restaurants, entertainment venues, or laboratories. Any unauthorized commercial use will void the warranty and the user will be responsible for any consequences.

22. Warning: Do not use the ice machine outdoors or expose it to rain. Place the machine in a well-ventilated room, ensuring there are no obstacles around it. Maintain unobstructed airflow and prevent direct

sunlight from shining on the machine. Ensure that the front, back, left, and right sides of the machine have at least 300mm clearance from walls or other objects to facilitate proper heat dissipation.

23. Do not overturn or tilt the machine, as this may cause abnormal noise, inconsistent ice size, or water leakage in severe cases. If the machine has been recently moved indoors from a cold outdoor environment during winter, allow it to reach room temperature before turning it on.

24. Warning: Only electrical appliances recommended by the manufacturer may be used inside the appliance's food storage area. Use only drinking water that complies with local drinking water standards. It is not recommended to use distilled water or tap water, as this may cause machine abnormalities, such as water sensor failure or machine water channel blockage.

25. Warning: Do not use mechanical devices or other unauthorized methods to accelerate the defrosting process. Avoid damaging the refrigeration circuit. The system uses R600a flammable refrigerant gas; if the refrigeration pipeline is damaged, keep away from open flames.

26. The refrigeration system contains high-pressure refrigerant and must not be damaged. Exercise caution during installation and transportation. Installation and maintenance must be performed exclusively by the manufacturer or qualified professionals. Dispose of the appliance through authorized recycling channels.

27. The ice maker contains thermal insulation materials which are flammable. Keep the appliance away from fire. Maintenance and disposal must be handled by the manufacturer or authorized professionals. Do not burn discarded parts privately.

- 28.** When transporting or moving the machine, ensure the tilt angle does not exceed 45 degrees.
- 29.** Do not invert or place the machine horizontally, and avoid pulling the power cord. After transportation or handling, allow the machine to rest for 24 hours before use. If the power supply is interrupted by unplugging the machine or power outage (not via the control panel), the compressor will enter protection mode and will typically resume normal operation after running for approximately 5 to 10 minutes.
- 30.** If the machine will not be used for an extended period, drain the water from the ice compartment.

Schematic View

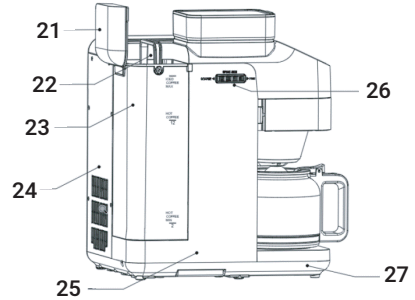
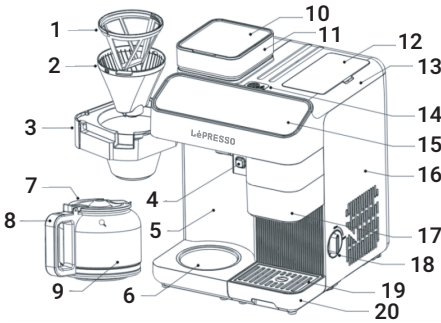

- 1.** Strainer
- 2.** Funnel
- 3.** Funnel Bin
- 4.** Button to Open Funnel Bin
- 5.** Front Cover
- 6.** Insulation Board
- 7.** Lid of Pot
- 8.** Handle
- 9.** Glass Pot
- 10.** Lid of Bean Box
- 11.** Bean Box
- 12.** Window Cover of Ice Maker
- 13.** Upper Cover
- 14.** Steam Lid

15. Operation Panel

16. Right Cover

17. Shelf Cover of Ice Dispensing

18. Drain Knob

19. Cover of Drainage Tray

20. Drainage Tray

21. Cover of Water Tank

22. Handle of Water Tank

23. Water Tank

24. Back Cover

25. Left Cover

26. Adjustment Knob for Coarse and Fine

27. Bottom Cover

Control Panel Guide

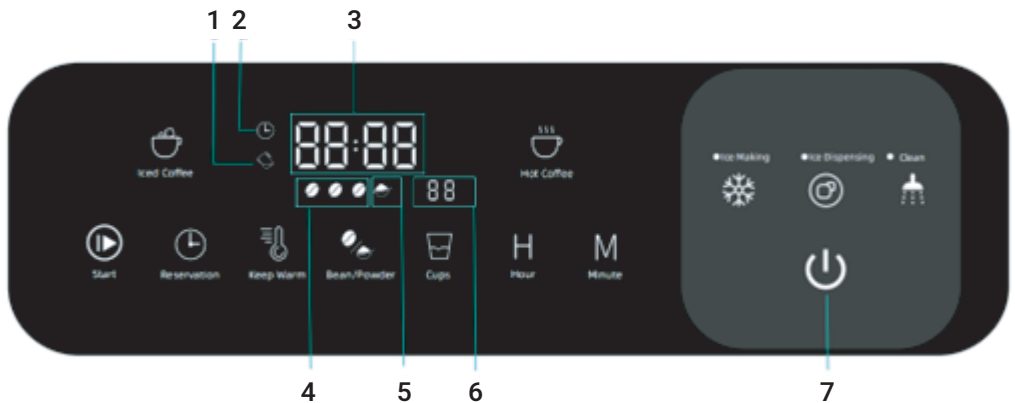

1. Water Shortage Indicator

2. Reservation Indicator

3. Time Display

4. Grinding Amount Indicator

5. Power Indicator

6. Coffee Powder Indicator

7. Power Supply Working Indicator

Specifications

Rated Voltage	220-240V
Rated Frequency	50Hz
Heating Power	1000W
Total Power	1300W
Power Cord	UK 3-Pin Plug
Water Tank Capacity	2.6L
Bean Box Capacity	250g
Ice Making Cycle	5-6 Times
Refrigerant	R600a
Net Weight	13kg
Product Dimension	363 x 338 x 451 mm

Instructions for Use

- 1. Remove all labels and packaging materials from the coffee machine. Verify that all accessories are included and free from damage.**
- 2. Clean the removable parts and accessories such as the water tank, funnel, and glass pot with warm water, then rinse thoroughly with clean water. Use a soft, damp cloth to wipe the exterior shell, coffee bean box, and other non-removable components to ensure cleanliness and ease of use.**

- 3.** Fill the water tank with pure drinking water up to the MAX level which holds 2.6 liters.
 - 4.** For brewing 2 cups of coffee, fill the water tank to the HOT COFFEE MIN 2 level corresponding to 2 cups or 0.3 liters. For brewing 12 cups, fill the water tank up to the HOT COFFEE 12 level.
 - 5.** When preparing iced coffee, ensure the minimum water level is not below the ICED COFFEE MIN level which corresponds to at least 5 cups or 1.1 liters.
 - 6.** Do not exceed the Max water level in the water tank. The tank is detachable; ensure it is properly seated and securely placed before operating the machine as shown in the illustration.
 - 7.** Verify that all accessories are correctly installed in their designated positions. Once confirmed, plug the power cord into the power socket. You will hear a "beep" sound, and all buttons along with the display screen will illuminate for one second before turning off. The machine is now in standby mode and ready to be turned on.
- a.** Pick up the water tank handle and lift the water tank carefully.

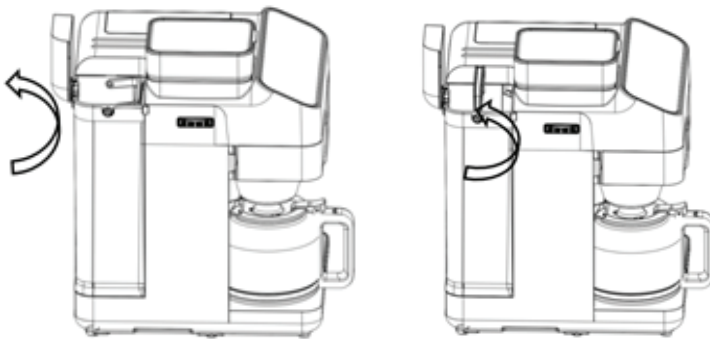

Figure a

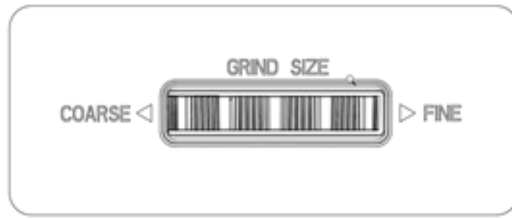

Figure c

b. Open the bean box and add coffee beans.

c. Adjust the grinding coarseness setting.

c.1 Turn the knob toward the coarse direction to select a coarser grind.

c.2 Turn the knob toward the fine direction to select a finer grind.



Figure d

d. Filling the Bean Box

d.1 The bean box has a capacity of 250 grams.

d.2 When the coffee beans are nearly used up, be sure to add beans promptly.

d.3 After adding the coffee beans, securely close the bean box lid to prevent moisture from affecting the beans.

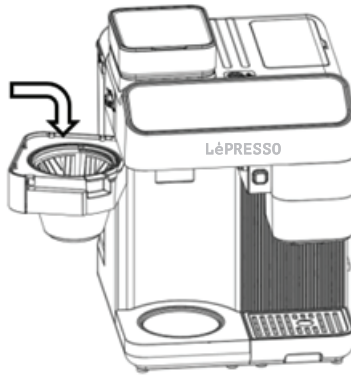



Figure e

e. Using Coffee Powder

- e.1** Add coffee powder to the coffee basket, ensuring the amount does not exceed 100 grams.
- e.2** When operating with coffee powder, be sure to select either Iced Coffee or Hot Coffee powder mode.
- e.3** Selecting the incorrect mode may result in improper operation.

Power Button Guide

Press the Power button "  " and release it when the buzzer sounds. The default time displayed on the digital screen is 12:00, with the seconds indicator flashing. Use the Hour and Minute buttons to set the current time. While setting, the entire display will flash and will automatically confirm the time after five seconds of inactivity.

Note: Press and hold the power button for 3 seconds to enter standby mode.

Making Iced Coffee

- 1.** Press the Iced Coffee button. The button light will be on, the single bean indicator will illuminate, the iced coffee operation indicator will turn on, and the cup number indicator will display the default setting of 5 cups.
- 2.** Press the Start/Stop button again. The ice-making indicator will remain solid, indicating that the machine has entered iced coffee mode.
- 3.** After selecting the Iced Coffee button, press the Cups button repeatedly to cycle through the number of cups: 5 ,6 ,7, or 8 cups.
- 4.** After selecting the Iced Coffee button, press the Bean/Powder button to switch between 1 ,2, or 3 bean settings, increasing the amount of coffee ground accordingly.
- 5.** The corresponding iced coffee cup volumes are: 5 cups – 375 ml, 6 cups – 450 ml, 7 cups – 525 ml, and 8 cups – 600 ml.

Note: The recommended ratio for iced coffee is one cup of coffee to one portion of ice. Filling the water tank once allows the machine to make up to 8 cups of iced coffee. The minimum iced coffee quantity is 5 cups, which corresponds to 5 portions of ice. For 6 cups, 6 portions of ice can be added. The machine can produce ice six consecutive times before the ice bin is full. When preparing 7 or 8 cups of iced coffee, some ice must be removed from the ice-making bin to continue making iced coffee without interruption.

Making Hot Coffee

- 1.** Press the Hot Coffee button. The button light will be on, the single bean indicator will illuminate, the hot coffee operation indicator will turn on, and the cup number indicator will display the default setting of 2 cups. At this point, press the Start/Stop button again.
- 2.** The hot coffee button light will become steady, indicating that the machine has entered the hot coffee brewing mode.
- 3.** After selecting the Hot Coffee button, press the Cups button repeatedly to cycle through the number of cups: 2 ,4 ,6 ,8 ,10, or 12 cups.
- 4.** After selecting the Hot Coffee button, press the Bean/Powder button to switch between 1 ,2, or 3 bean settings, increasing the amount of coffee ground accordingly.

Time Setting

- 1.** Press the Hour button to increase the hour and the Minute button to increase the minutes. Pressing and holding either button will accelerate the adjustment.
- 2.** When setting the power-on time, the hour, minute, and second digits on the display will flash along with the seconds indicator.
- 3.** After completing the time setting, if there is no activity for 5 seconds, the digits will stop flashing while the seconds indicator continues to flash, and the current time will be maintained.

Reservation Button

1. Press the Reservation button to enter the reservation mode. The entire digital display and the seconds indicator will begin to flash. After setting the desired reservation time, if no further input is made within 5 seconds, the digits will stop flashing, the seconds indicator will turn off, and the current time will be confirmed. At this point, the reservation indicator will illuminate.

2. Once the current time is set, you can proceed to set the reservation start time. Upon the initial power-on, press the Hour (H) or Minute (M) buttons to adjust the reservation start time.

Note: While in reservation mode, the current time cannot be adjusted. To modify the current time, the reservation function must be canceled first.

3. After 3 seconds, the upper left corner of the display will light up, the Reservation button indicator will turn off, and the machine will enter automatic reservation mode.

4. When the scheduled reservation time is reached, the Reservation indicator will turn off, the iced coffee or hot coffee indicator will illuminate, and the machine will automatically start the brewing cycle. Upon completion, it will return to standby mode.

Important: The reservation function can only be activated after the current time has been correctly set.

Keep Warm Function

1. In the hot coffee mode, the machine will automatically activate the keep warm function upon completion of the brewing cycle, indicated by the illumination of the keep warm indicator light.
2. To deactivate this function, press the Keep Warm button. After the preset duration elapses, the indicator light will turn off, and the machine will enter standby mode. The default keep warm duration is 2 hours, with an adjustable range from 0 to 24 hours.

Note: By default, the keep warm function is available only for the Hot Coffee and coffee powder modes, with a standard duration of 2 hours. The Iced Coffee mode does not support the keep warm feature, and therefore, the keep warm indicator light will not activate upon completion.

Ice-Making Function

1. Press the Ice Making button "" to activate the compressor and other components of the ice-making system. Open the window cover to monitor the ice-making status, including the initial ice production, timing, and operational efficiency.

Warning: When positioning the machine, ensure that the heat dissipation vents are not obstructed by any objects.

Flip the window cover to monitor the ice-making status.

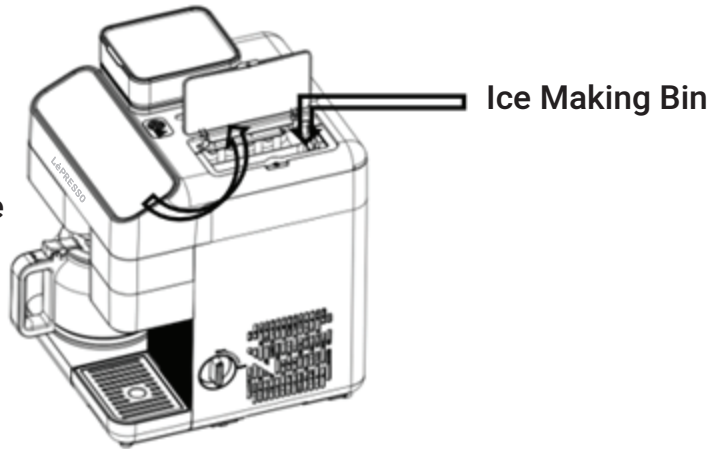

2. Press the "  " button. The ice in the ice-making bin will form into round shapes, and ice will be produced continuously.

3. The ice-making bin is equipped with a built-in water tank and a waste water cleaning system.

Turn the drain knob to OPEN to drain the remaining water in the ice maker water tank.

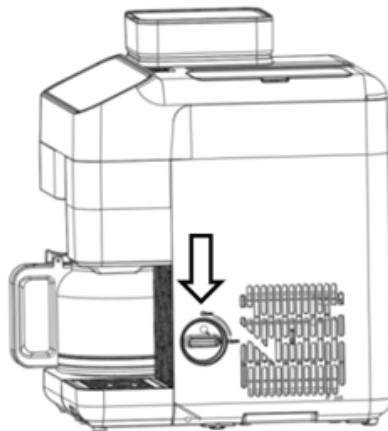







Pull out the tray. Pour out the waste water.



Indicator and Icon Guide



Status	Description	Instruction
The Start/Stop indicator is off.	The machine coffee zone is paused or in standby mode.	Press the button to turn on the machine.
The Iced Coffee indicator is on.	The Iced Coffee function is already active.	Press the Iced Coffee button, then press Start/Stop button.
The Iced Coffee indicator is on.	The Iced Coffee function is either being prepared or paused.	During the Iced Coffee operation, press Start to pause the process.
The Hot Coffee indicator is on.	The Hot Coffee function is already active.	Press the Hot Coffee button, then press Start to begin the operation.
The Hot Coffee indicator is on.	The Hot Coffee function is either being prepared or paused.	During the Hot Coffee operation, press Start to pause the process.

<p>The grind amount indicator lights up for 1 bean, 2 beans, and 3 beans, respectively.</p>	<p>When Iced Coffee or Hot Coffee is selected, the coffee beans are working; the more beans used, the more powder is produced.</p>	<p>Press the Bean/Powder button to cycle through the settings for 1 bean, 2 beans, and 3 beans.</p>
<p>The Coffee Powder Working indicator is on. </p>	<p>When Iced Coffee or Hot Coffee is selected, the coffee powder is working.</p>	<p>Press the Bean/Powder button to cycle through the coffee powder options.</p>
<p>The Cup Number Adjustment indicator is on. </p>	<p>Select CUPS to adjust the cup quantity.</p>	<p>Press the button to cycle through the number of cups.</p>
<p>The Keep Warm indicator is on.</p>	<p>Iced coffee does not keep warm, but hot coffee does.</p>	<p>Long press the keep warm button to cancel keep warm, then press it again to turn it on.</p>
<p>The Clean icon is on.</p>	<p>The Clean function is active.</p>	<p>Press the Clean button to initiate the cleaning process.</p>
<p>The Reservation indicator is on.</p>	<p>The Reservation function is active.</p>	<p>Press the Reservation button to adjust the hour and minute, then press Iced Coffee or Hot Coffee to schedule the operation.</p>
<p>The Water Shortage indicator is on. </p>	<p>The water tank is low on water.</p>	<p>You need to add water to the water tank.</p>
<p>The  indicator icon is on.</p>	<p>The Coffee Cup Count indicator is on.</p>	<p>Press Iced Coffee or Hot Coffee, then press the button continuously to switch the number of cups.</p>
<p>The  button.</p>	<p>The Ice Making is active.</p>	<p>Press the button to begin making ice.</p>

The  button	The Ice Dispensing is active.	Press the button to begin dispensing ice.
The  button	The Power Switch is set to ON/OFF.	Press the button to turn on the machine.

Cleaning Guide

Proper maintenance and regular cleaning can extend the equipment's lifespan and significantly reduce the risk of scale buildup. Select "cleaning" after a period of use. Follow these steps:

1. Fill the water tank with pure water up to the "MAX" water level.
2. Place the glass pot in position.
3. Click the power icon  , choose the cleaning icon  . The machine will automatically enter the cleaning process.
4. After the cleaning function is completed, the cleaning icon will turn off, and the machine will return to standby mode.
5. Cleaning can be performed multiple times based on actual conditions.

4. Important Tips

- 4.1 Before cleaning the exterior of the machine, always turn it off, unplug it from the power socket, and allow the machine to cool down.
- 4.2 Never use chemical solvents, abrasive cleaners, or alcohol to clean the coffee machine.
- 4.3 Avoid using metal objects to descale or remove coffee deposits,

as they may scratch the metal or plastic surfaces of the machine.

4.4 If the machine has been idle for a week or longer, it is recommended to run a cleaning cycle before using it again.

4.5 Never submerge the machine in water for cleaning.

5. Clean the Funnel Compartment

As shown in the image, coffee powder residue will accumulate in the funnel compartment after use. To prevent this residue from falling into the coffee filter and affecting the taste, use a cleaning brush to promptly clean the compartment. This ensures that every cup of coffee remains fresh.

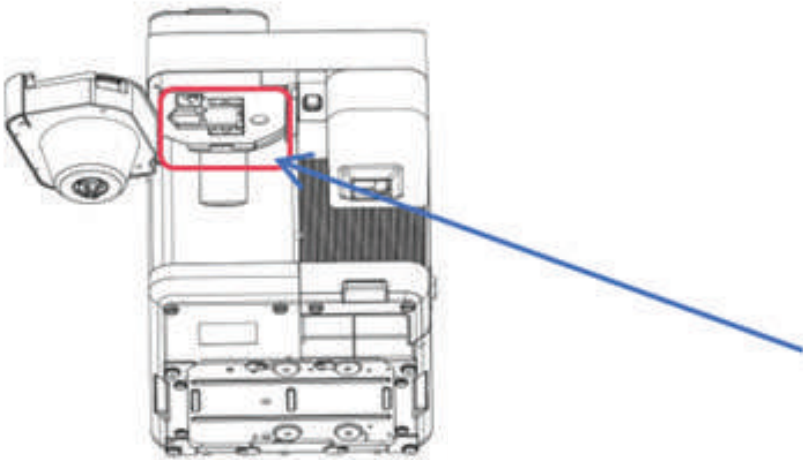

6. Clean the Funnel Bin

As shown in the figure, after multiple uses, coffee powder residue will accumulate at the bottom of the funnel bin. To maintain cleanliness, use a brush to clean the bin promptly.

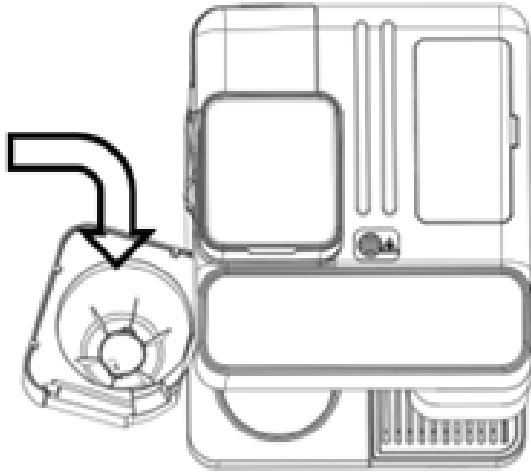

7. Daily Cleaning and Maintenance of the Grinder

During use, the powder outlet may become blocked due to the influence of coffee beans and external factors. If you notice a decrease in powder output, it is important to clean the powder outlet promptly. Use a cleaning brush, as shown in the figure below, to ensure the outlet remains clear.

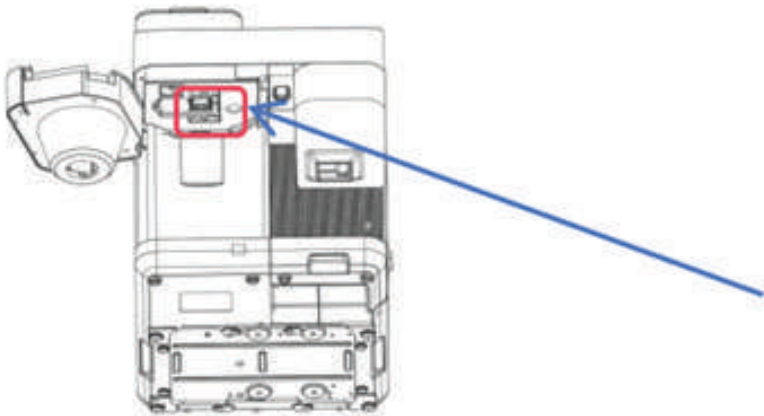

7.1 Warning

- a.** The grinder is equipped with an overload protection safety feature. If the grinder is overloaded, it will automatically stop working. After the protection period of approximately 20 minutes, the grinder will resume normal operation.
- b.** When cleaning the powder outlet channel, ensure that there are no beans left in the bean box. Press the Hot Coffee button to allow the grinder to operate normally and grind any remaining beans until the bean box is empty.
- c.** Do not rinse the bean box directly with water.

8. Ice Making Bin Cleaning

- 8.1** Before cleaning, activate the drain knob on the side wall of the machine to direct water from the ice-making tank to the waste water tank.
- 8.2** Once the water is drained, turn off the drain knob. Press the "Clean" button to begin the cleaning cycle, which lasts approximately 15 minutes.
- 8.3** To stop the cleaning process, press the "Clean" button again.
- 8.4** After cleaning, open the drain knob again to drain the water from the ice-making tank to the waste water tank. Once the tank is emptied, turn off the drain knob.
- 8.5** During both the cleaning and drainage processes, regularly check the waste water tank. Empty the tank as needed to prevent overflow.

9. Evaporator Column Cleaning

Use either water or alcohol to clean the evaporator column.

10. Clean the Glass

Regularly rinse with clean water to prevent residue from affecting the taste.

11. Clean the Main Water Tank

Regularly clean the inside of the water tank with a clean towel. Remember to empty the waste water tank periodically.

12. Cleaning the Body

Before cleaning, unplug the power and allow the unit to cool down. Dampen a clean towel with water and add a few drops of mild detergent to wipe the surface. Avoid using solvents that may damage the plastic.

Troubleshooting

	Problem	Possible Cause	Solution
Coffee section	Cannot make coffee or the flow is too slow.	There is no water in the water tank.	Add pure water to the water tank.
		The water tank is not fully inserted into the machine.	Install the water tank correctly and press it down completely.
		The coffee filter is excessively dirty and needs cleaning.	Rinse the coffee net with running water.
		The bottom grid of the water tank is clogged with coffee residue.	Use a brush to clean the coffee net.

		Scale has built up in the water circuit of the heating tube.	Refer to the cleaning section for cleaning instructions.
	Coffee flows out too fast and tastes weak.	The coffee powder is ground too coarsely, impacting extraction.	Try using a finer grinding gear.
		There is too little coffee powder used for brewing.	Increase the amount of powder in the powder cup appropriately.
	The machine does not grind coffee.	A foreign object is obstructing the coffee grinder, preventing it from grinding the coffee beans.	Refer to the daily cleaning and maintenance instructions for the grinder.
		The internal protection mechanism of the grinding motor has been activated due to overuse or blockage.	Remove the 4 screws on the top bean box and clean out any hard foreign objects or debris stuck in the grinder.
Ice making section	The "Lack of water" indicator is on. The "Ice" button flashes.	1. Lack of water. 2. The filter at the bottom of the water tank is blocked.	1. Stop the ice-making process, add water, and press the "power" button to restart ice production. 2. Perform cleaning.
		1. Too many ice cubes in the ice basket. 2. The ice full sensor is broken, causing the "ice making" button to flash even when the basket is not full.	1. Press the "ice out" button to remove the ice cubes from the ice basket. 2. Reach out to a service center for sensor replacement.

Ice cubes are stuck together.	The water temperature in the water tank is too low.	Replace the water in the water tank, ensuring the water temperature is between 8°C and 32°C.
The ice basket is full, but the machine is still making ice.	<ol style="list-style-type: none"> 1. Strong ultraviolet rays at the machine's location are affecting infrared ray detection. 2. The ice full sensor is malfunctioning. 	<ol style="list-style-type: none"> 1. Relocate the machine to a darker area. 2. Contact a service center to replace the sensor.
Ice making is normal, but no ice cubes are produced.	<ol style="list-style-type: none"> 1. The ambient temperature or water temperature is too high. 2. The refrigeration system is leaking. 3. The refrigeration system is blocked. 	<ol style="list-style-type: none"> 1. Make ice when the ambient temperature is below 32°C and ensure the water tank contains an appropriate amount of cold water. 2. Contact a service center for assistance.
The ice box cannot be turned over normally or the turning signal is faulty.	<ol style="list-style-type: none"> 1. The micro switch is broken. 2. The full ice sensor is broken. 	Contact after-sales service
No ice	<ol style="list-style-type: none"> 1. There is no ice in the ice storage box. 2. There is ice in the ice storage box, and the ice outlet is stuck when discharging ice. 	<ol style="list-style-type: none"> 1. Press the ice dispensing button again after making ice. 2. Press the ice dispensing button, open it again after 5 seconds, and repeat 3 times.
The ice is too thin.	<ol style="list-style-type: none"> 1. The ambient temperature is high. 2. The ventilation is not smooth. 	<ol style="list-style-type: none"> 1. Lower the machine and move it to a low temperature place. 2. The distance between the back and left and right sides of the machine and the obstacles is greater than 300mm.

List of Food Contact Materials

This product is designed for safe contact with food. Please use it according to the provided instructions.

The materials and components in contact with food meet FCM requirements and relevant national food safety standards. The specific details are as follows:

Component	Material	Standard	Testing Requirements
The front cover, funnel bin, bean box, steam cover, funnel, shower bottom cover, coffee spoon, filter check valve, one-way pipe, filter bracket, filter, water valve bracket, three-way connector, and glass cover	PP	GB4806.7-2023	Complies with a set of regulations established by the U.S. Food and Drug Administration (FDA), which govern the safety, effectiveness, and compliance of food, drugs, medical devices, and other related products.
The bean box cover, bean box baffle, powder outlet, powder channel cover, ice box, ice storage bin, and ice making viewing window.	ABS	GB4806.7-2023	
The powder sealing port shower rack, powder outlet bottom pad rack, powder outlet inner rotating bracket, NTC rack, bean grinding adjustment rack, external grinding rack, grinding head guide column, and powder sweeping rack.	PA66	GB4806.7-2023	

Water tank	AS	GB4806.7-2023
External grinding disc, internal cone knife	External grinding disc, internal cone knife	GB4806.9-2023
Cap nut, sealing rod, sealing piece, spring	Stainless steel SUS304	GB4806.9-2023
Sealing ring, silicone tube	Air Rubber/Silicone	GB4806.11-2016
Strainer	Nylon	GB4806.7-2023
Sealing frame, PTFE sealing sheet	Polytetrafluoroethylene	GB4806.7-2023
Glass pot	High boron glass	GB4806.5-2016
Diaphragm pumps	PP+GF+silicone	GB4806.7-2023
Flow meter	PBT	GB4806.7-2023
NTC header	Stainless steel SUS304	GB4806.9-2023

Environmental Checklist

Parts	Toxic and hazardous substances or elements:					
	Lead (Pb)	Mercury (Hg)	Cadmium (Cd)	Hexavalent Chromium (Cr(VI))	Poly-brominated Biphenyls (PBB)	Poly-brominated Diphenyl Ethers(PBDE)
PCBA	✗	○	○	○	○	○
Power Line	○	○	○	○	○	○
Motor	○	○	○	○	○	○
Plastic Parts	○	○	○	○	○	○
Metal Parts	○	○	○	○	○	○

This table is compiled according to the rules of IEC62321.

O: Indicates that the content of the hazardous substance in all homogeneous materials of the component is below the limit requirement specified in IEC62321.

X: Indicates that the content of the hazardous substance in at least one homogeneous material of the component exceeds the limit requirement specified in IEC62321. However, the content of the components marked with "X" exceeds the limit because there is no mature alternative technology in the industry.



The number in this mark indicates that the environmentally friendly use period of the product under normal use is 10 years.

This means that the hazardous substances contained in this product will not leak or mutate, and the user's normal use of this product under the conditions described in the product manual will not cause serious pollution to the environment or cause serious damage to personal property.

Disposal



Indicates that this product is recyclable. If it exceeds its service life or fails to work properly after repair, it should not be discarded indiscriminately. Please hand it over to formal recycling channels or companies qualified to handle waste electrical and electronic products. For correct disposal, refer to the national or local regulations on the disposal of old electrical and electronic products.

Warranty

Products that you buy directly from our **LePresso** website or shop come with a 24-month warranty.

The 24-month warranty applies to products purchased directly from our **LePresso** website or store. If **LePresso** products are bought from any of our verified retailers, then the product is eligible for only a 12-month warranty. To extend your product's warranty, visit our website <https://www.lepresso.com/warranty> and fill in your details in the provided form along with an uploaded picture of the product to process your request. Once approved, you will receive a confirmation email of the extended product warranty. Upload the required information within 48 hours of purchase to be eligible for a 24-month warranty period.

For more info, please check:

<https://www.lepresso.com/warranty>

Contact Us

If you have any questions or concerns about our Shipping and Returns Policy, please contact us at: info@lepresso.com

Website: <https://www.lepresso.com/>

Instagram: [lepresso_official](https://www.instagram.com/lepresso_official)